

# Multi-Point Lock Keeper

Part Number	Material	Hand
19030R1	Steel	RH
19031R1	Steel	LH

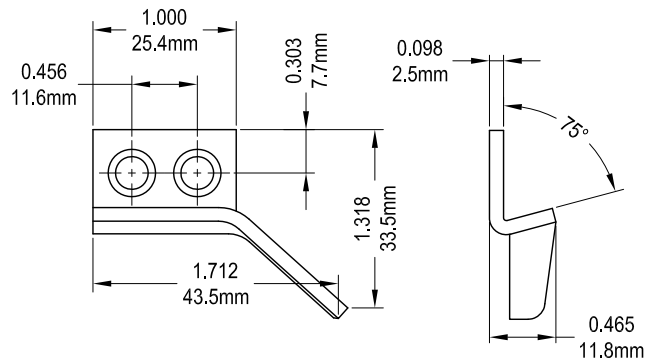

Part Number	Material	Hand
19033	Steel	LH
19034	Steel	RH

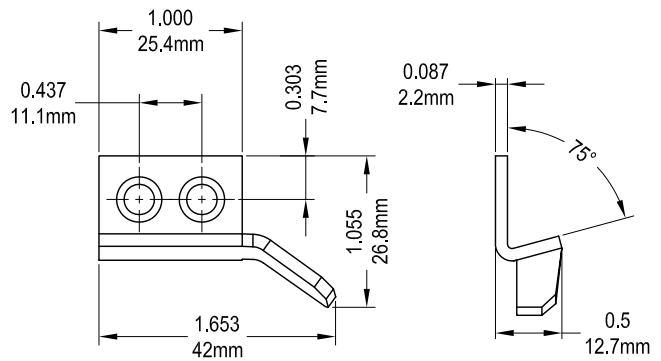

Part Number	Material	Hand
19037	Steel	RH
19038	Steel	LH

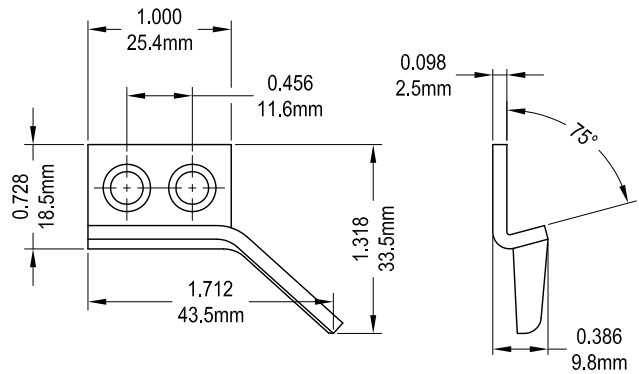

Part Number	Material	Hand
2040	Nylon	LH
2041	Nylon	RH

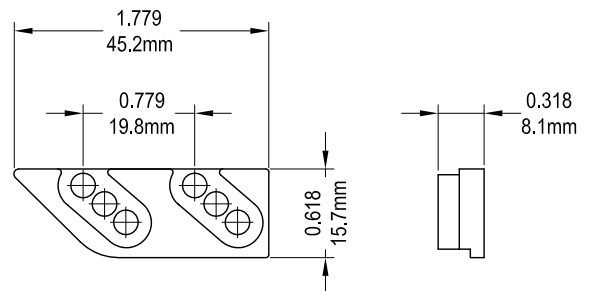

Note : Right Hand Shown  
(Left Hand Opposite)

Part Number	Material	Hand
7084	SST	RH
7085	SST	LH
19084	Steel	RH
19085	Steel	LH

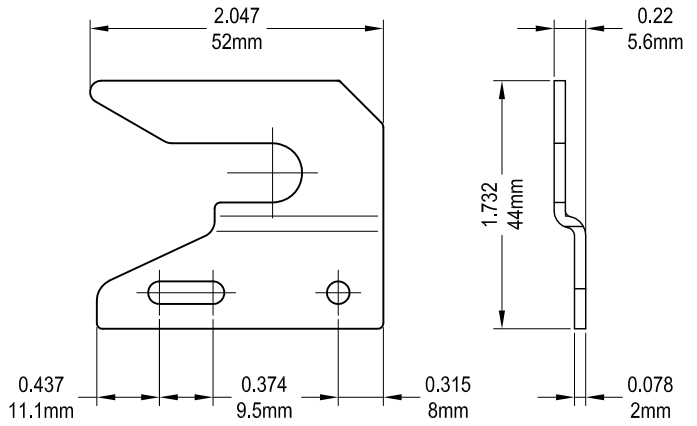

Part Number	Material	Hand
190485	Steel	LH
190486	Steel	RH

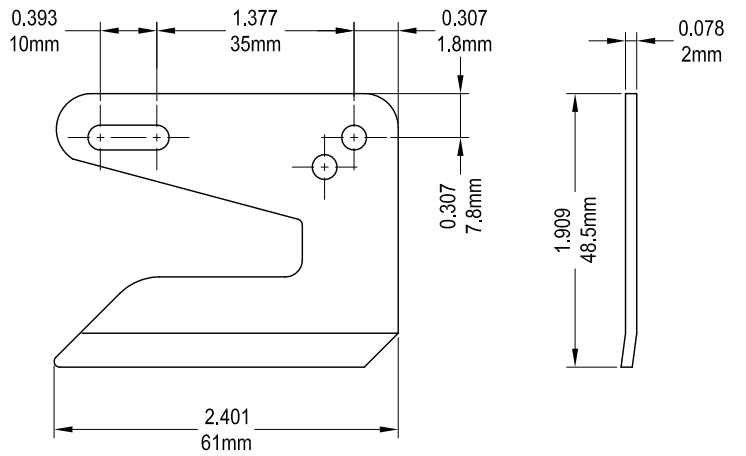

Part Number	Material	Hand
190487	Steel	LH
190488	Steel	RH

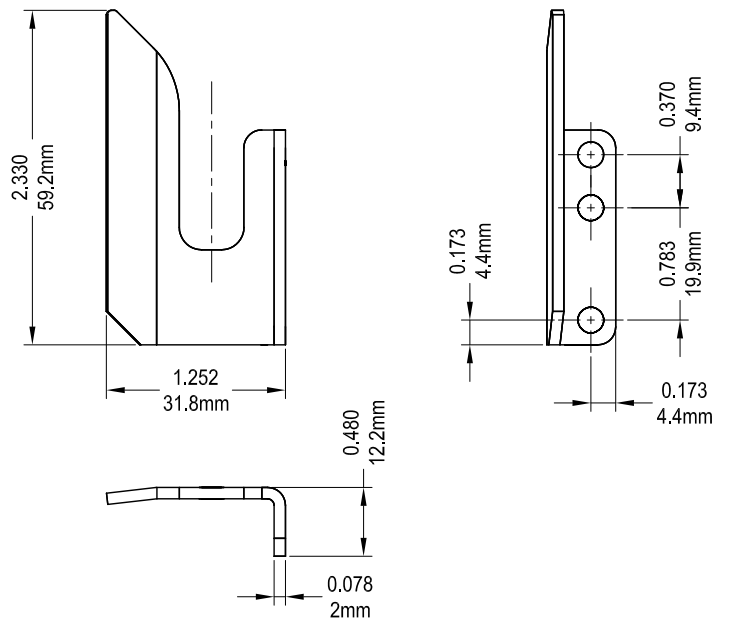

Note : Right Hand Shown  
(Left Hand Opposite)

Part Number	Material	Hand
19077	Steel	LH
19078	Steel	RH

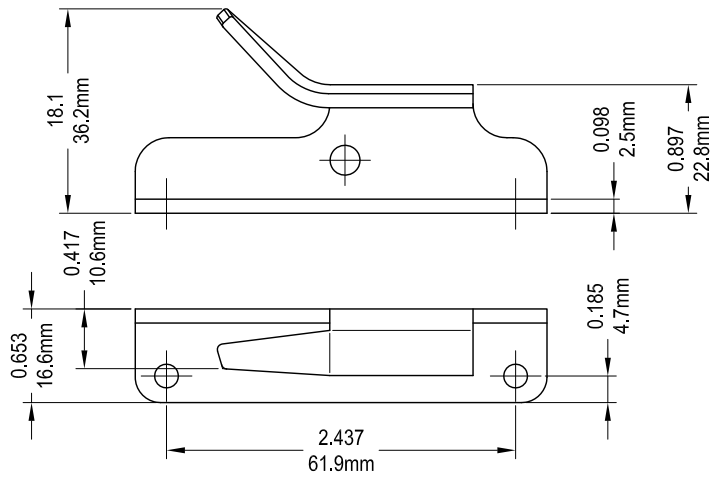

Part Number	Material	Hand
19028	Steel	LH
19029	Steel	RH

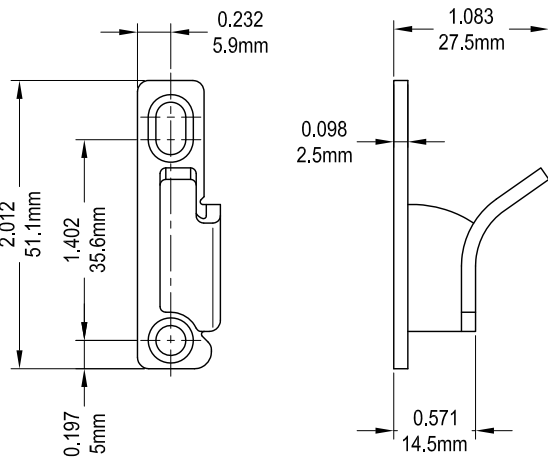

Part Number	Material	Hand
19053	Steel	LH
19054	Steel	RH

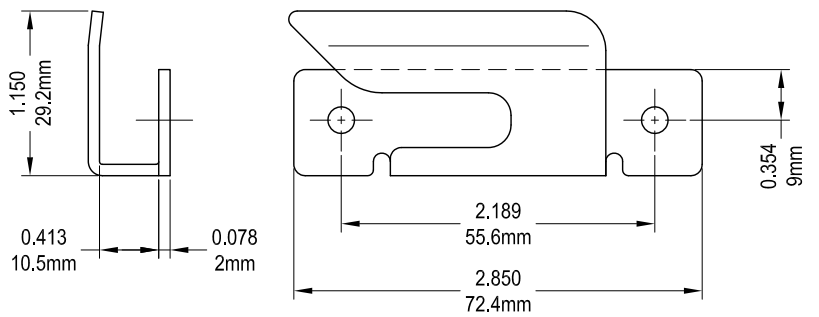

Note : Right Hand Shown  
(Left Hand Opposite)

Part Number	Material	Hand
19051	Steel	Non

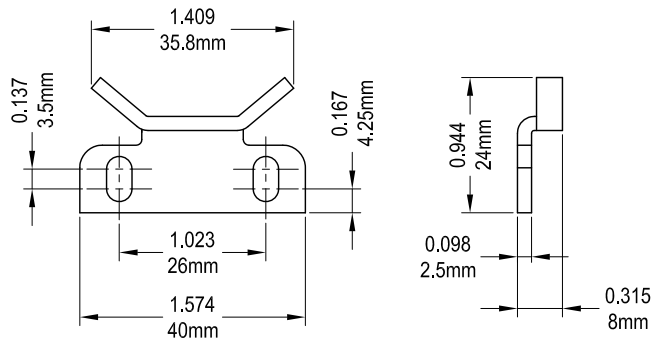

Part Number	Material	Hand
19052	Steel	Non

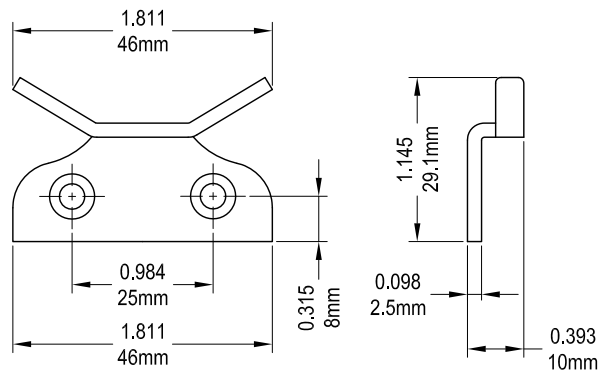

Part Number	Material	Hand
19055	Steel	Non
7055	SST	Non

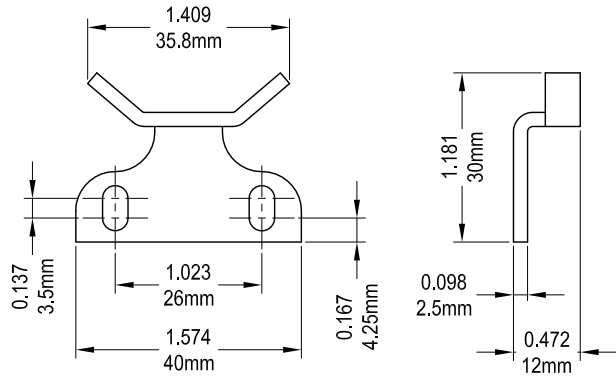

Part Number	Material	Hand
19058	Steel	Non

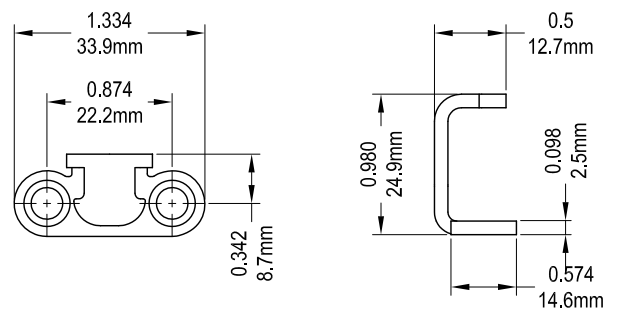

Part Number	Material	Hand
7070	SST	Non

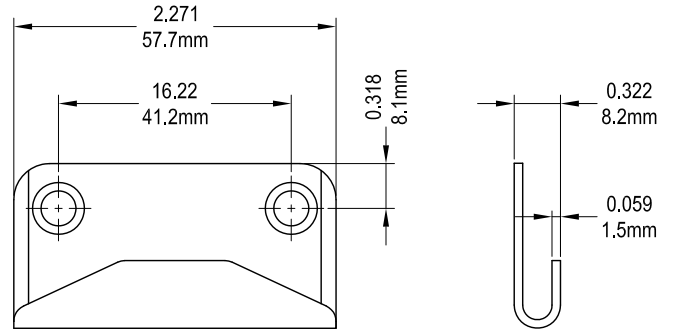

Part Number	Material	Hand
R196	Steel	Non
70196	SST	Non

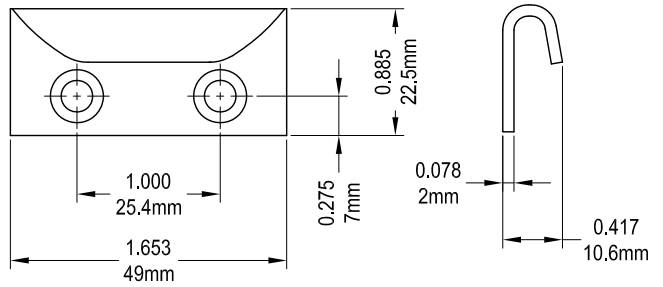

Part Number	Material	Hand
19050	Steel	Non

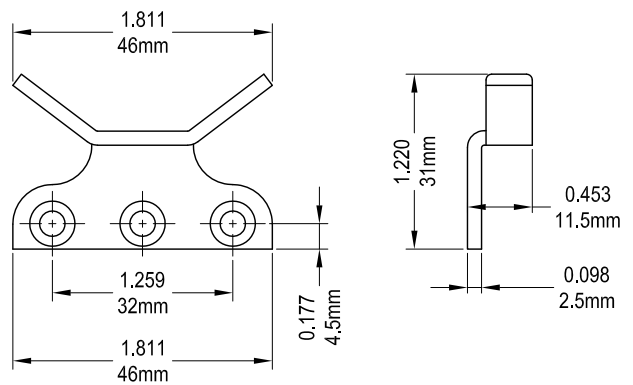

Part Number	Material	Hand
19074	Steel	Non

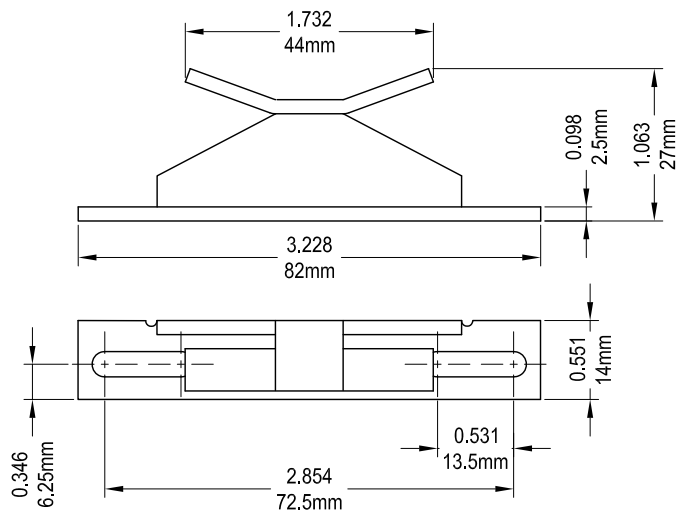

Part Number	Material	Hand
205501R1	Nylon	Non

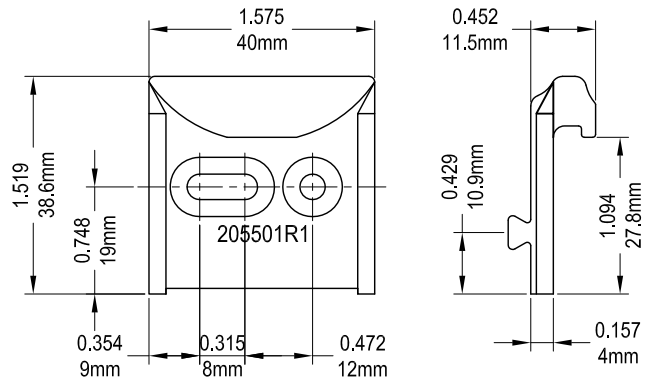

Part Number	Material	Hand
20550	Nylon	Non

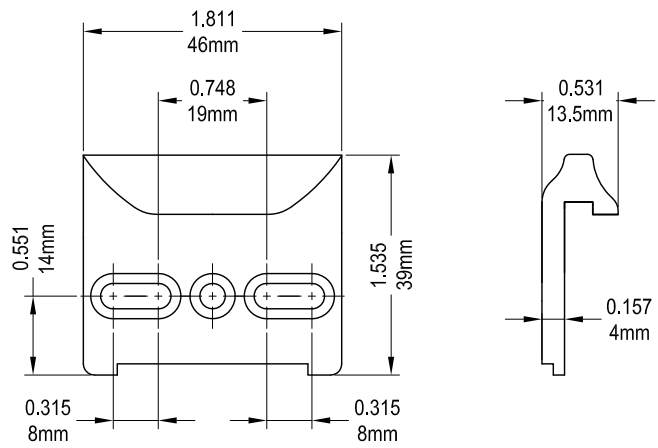

Part Number	Material	Hand
20554	Nylon	Non

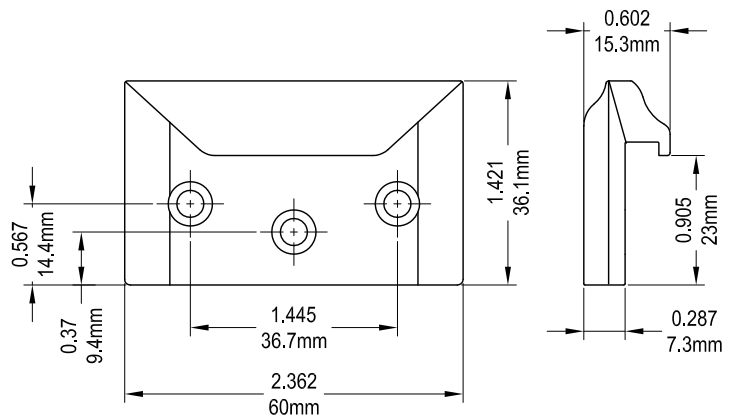

Part Number	Material	Hand
20552	Nylon	Non

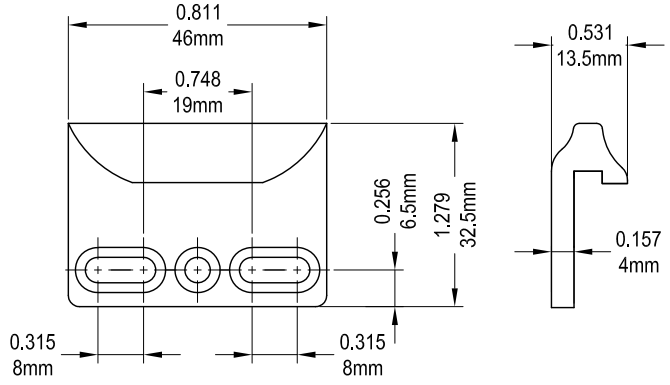

Part Number	Material	Hand
20560	Nylon	Non

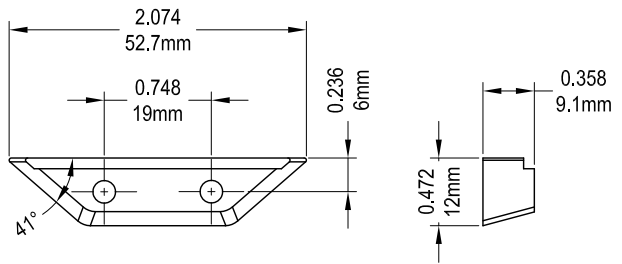

Part Number	Material	Hand
19079	Steel	Non

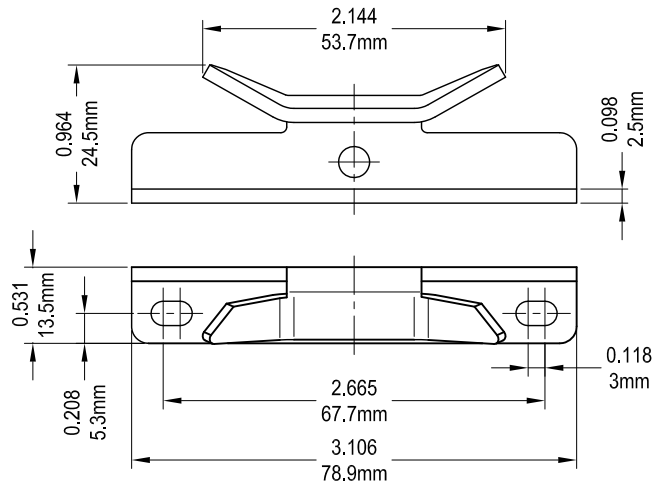

Part Number	Material	Hand
190489	Steel	Non

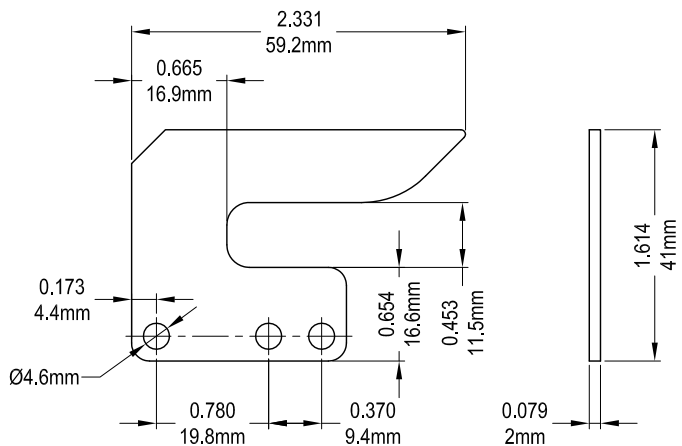

Part Number	Material	Hand
190492	Steel	LH
190493	Steel	RH

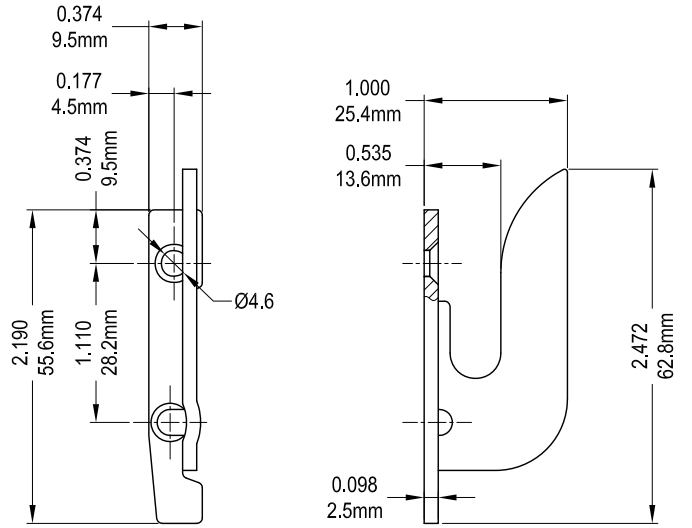

Part Number	Material	Hand
190495	Steel	LH
190494	Steel	RH

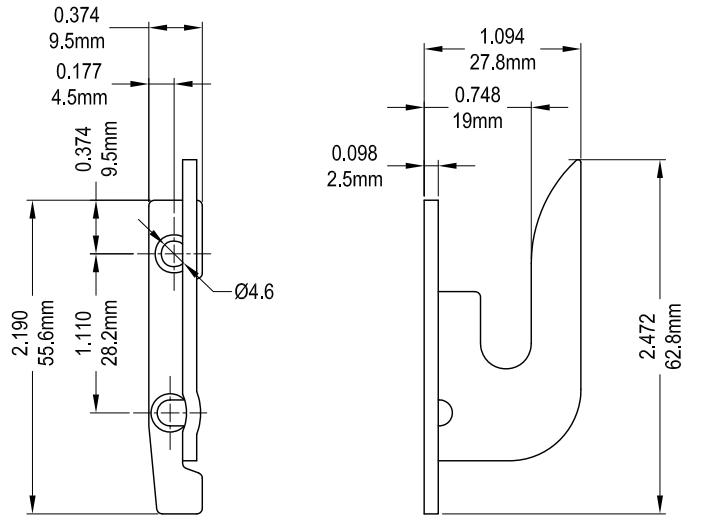

Part Number	Material	Hand
190496R1	Steel	RH
190497R1	Steel	LH

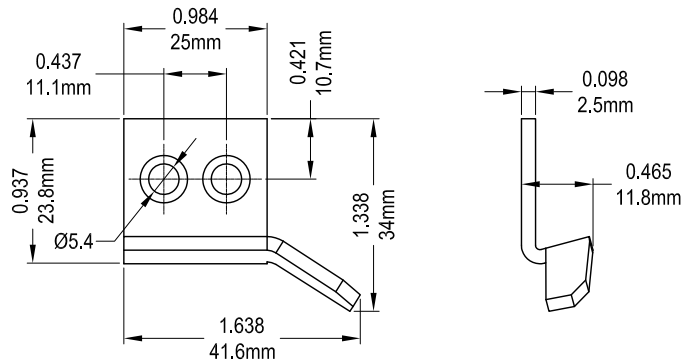

Note : Right Hand Shown  
(Left Hand Opposite)